

APPLICABLE EGRESS REQUIREMENTS TO BE REVIEWED BY AHJ.

ALL DOOR INSTALLATIONS MUST BE IN ACCORDANCE WITH EGS INSTALLATION INSTRUCTIONS.
ALL SEALANTS TO BE TREMCO SPECTREM 2.

DAYLITE OPENINGS:

D.L.O. HEIGHT = PANEL HEIGHT - 8.875"
D.L.O. WIDTH = PANE
PANEL HEIGHT = DOOR HEIGHT - 2"

THESE DOORS ARE RATED FOR SMALL MISSILE IMPACT.
F.B.C. APPROVED IMPACT RESISTANT SHUTTERS REQUIRED FOR INSTALLATIONS UP TO 30 FT. OF GRADE.
SHUTTERS NOT REQD. FOR INSTALLATIONS ABOVE 30 FT. OF GRADE.

ATLANTIC SERIES SM 130 ALUM SLIDING GLASS DOOR

SEE SHEET 2 FOR DESIGN LOAD CAPACITY OF DESIRED GLASS/REINF.

USING CHART ON SHEET 3 SELECT ANCHOR OPTION WITH DESIGN RATING MORE THAN DESIGN LOADS REQUIRED.

LOWER DESIGN PRESSURES FROM GLASS OR ANCHOR CHARTS WILL APPLY TO ENTIRE SYSTEM.

THIS PRODUCT HAS BEEN DESIGNED AND TESTED TO COMPLY WITH THE REQUIREMENTS OF THE 2020 (7TH EDITION)/2023 (8TH EDITION) FLORIDA BUILDING CODE INCLUDING HIGH VELOCITY HURRICANE ZONE (HVHZ).

1BY OR 2BY WOOD BUCKS & BUCK FASTENERS BY OTHERS, MUST BE DESIGNED AND INSTALLED ADEQUATELY TO TRANSFER APPLIED PRODUCT LOADS TO THE BUILDING STRUCTURE.

ANCHORS SHALL BE CORROSION RESISTANT, SPACED AS SHOWN ON DETAILS AND INSTALLED PER MANUF'S INSTRUCTIONS. SPECIFIED EMBEDMENT TO BASE MATERIAL SHALL BE BEYOND WALL DRESSING OR STUCCO.

A LOAD DURATION INCREASE IS USED IN DESIGN OF ANCHORS INTO WOOD ONLY.

ALL SHIMS TO BE HIGH IMPACT, NON-METALLIC AND NON-COMPRESSIBLE.

MATERIALS INCLUDING BUT NOT LIMITED TO STEEL/METAL SCREWS, THAT COME INTO CONTACT WITH OTHER DISSIMILAR MATERIALS SHALL MEET THE REQUIREMENTS OF THE 2020/2023 FLORIDA BLDG. CODE & ADOPTED STANDARDS.

THIS PRODUCT APPROVAL IS GENERIC AND DOES NOT PROVIDE INFORMATION FOR A SITE SPECIFIC PROJECT, i.e. LIFE SAFETY OF THIS PRODUCT, ADEQUACY OF STRUCTURE RECEIVING THIS PRODUCT AND SEALING AROUND OPENING FOR WATER INFILTRATION RESISTANCE ETC.

CONDITIONS NOT SHOWN IN THIS DRAWING ARE TO BE ANALYZED SEPARATELY, AND TO BE REVIEWED BY BUILDING OFFICIAL.

DESIGN LOADS SHOWN ARE BASED ON 'ALLOWABLE STRESS DESIGN (ASD)'.

MANUFACTURER'S LABEL SHALL BE LOCATED ON A READILY VISIBLE LOCATION IN ACCORDANCE WITH SECTION 1709.9.3 OF FLORIDA BUILDING CODE.
LABELING TO COMPLY WITH SECTION 1709.9.2.

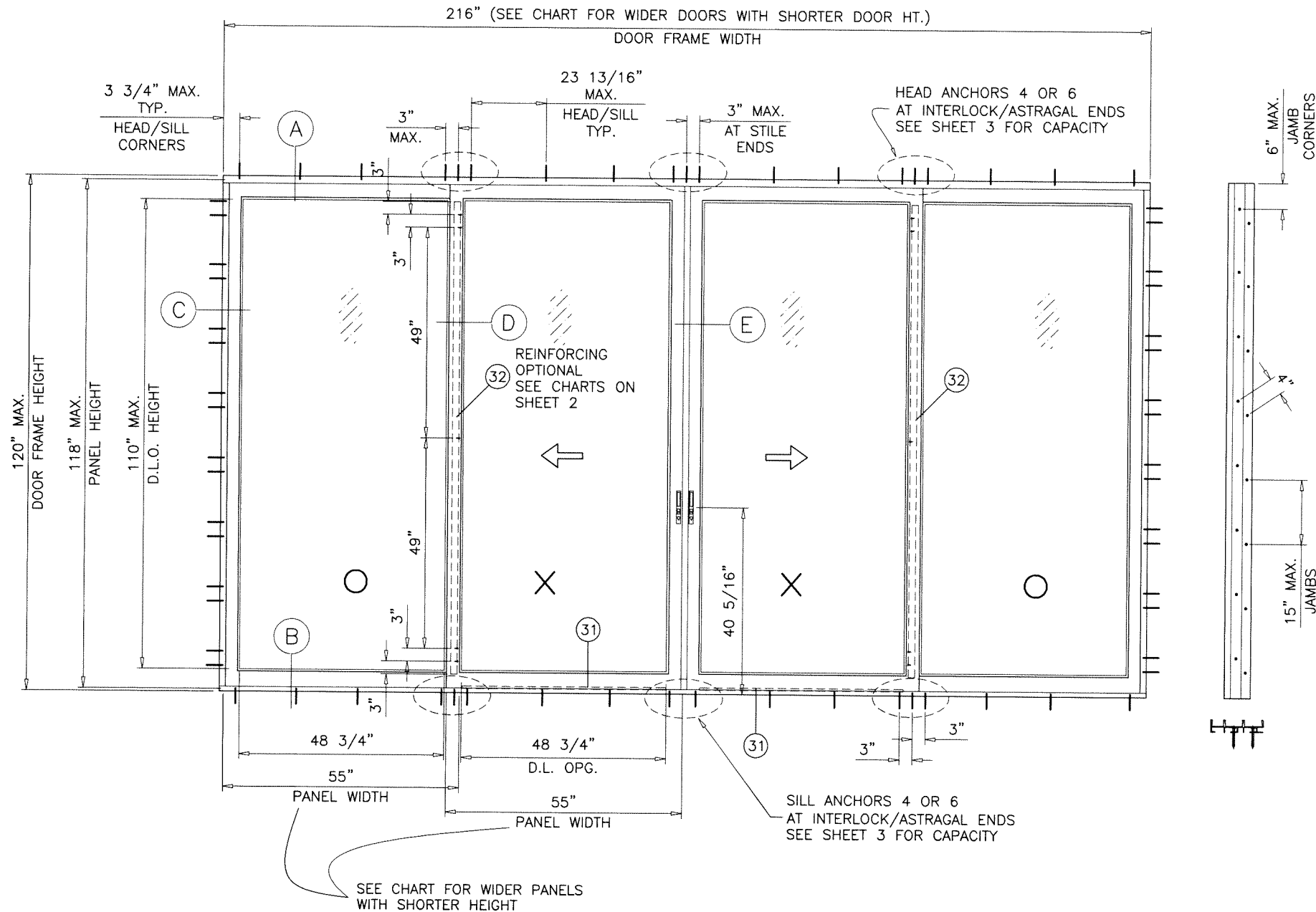

SEE CHART FOR WIDER PANELS WITH SHORTER HEIGHT

TYPICAL ELEVATION TESTED UNIT

- A- CONTRACTOR TO BE RESPONSIBLE FOR THE SELECTION, PURCHASE AND INSTALLATION OF THIS PRODUCT BASED ON THIS PRODUCT EVALUATION PROVIDED HE/SHE DOES NOT DEVIATE FROM THE CONDITIONS DETAILED ON THIS DOCUMENT.
- B- THIS PRODUCT EVALUATION DOCUMENT WILL BE CONSIDERED INVALID IF ALTERED BY ANY MEANS.
- C- SITE SPECIFIC PROJECTS SHALL BE PREPARED BY A FLORIDA REGISTERED ENGINEER OR ARCHITECT WHICH WILL BECOME THE ENGINEER OF RECORD (E.O.R.) FOR THE PROJECT AND WHO WILL BE RESPONSIBLE FOR THE PROPER USE OF THE P.E.D. ENGINEER OF RECORD, ACTING AS A DELEGATED ENGINEER TO THE P.E.D. ENGINEER SHALL SUBMIT TO THIS LATTER THE SITE SPECIFIC DRAWINGS FOR REVIEW.
- D- THIS P.E.D. SHALL BEAR THE DATE AND ORIGINAL SEAL AND SIGNATURE OF THE PROFESSIONAL ENGINEER OF RECORD THAT PREPARED IT.

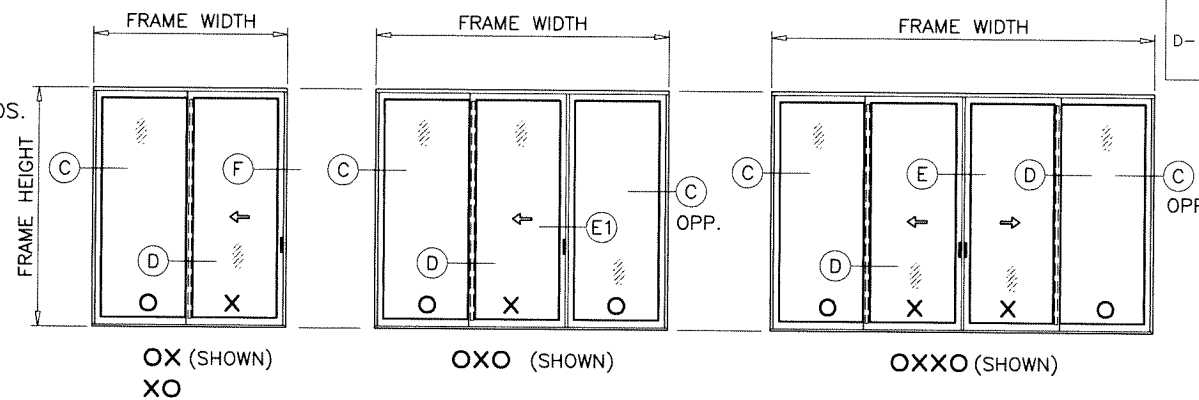

APPROVED CONFIGURATIONS

Sealed: 7/12/2023

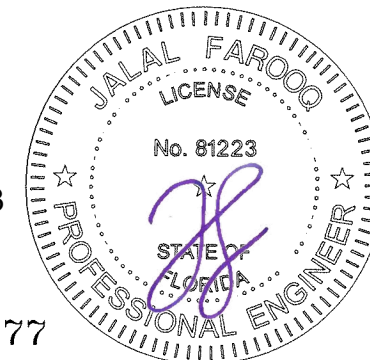

FL #29677

af c
AL-FAROOQ CORPORATION
ENGINEERS & PRODUCT DEVELOPMENT
9360 SUNSET DRIVE, SUITE 220
MIAMI, FLORIDA 33173 (C.A.N. 3538)
TEL. (305) 264-8100 FAX. (305) 262-6978
EGS\SM\19-46F-EGS

ATLANTIC SERIES SM 130 ALUM. SLIDING GLASS DOOR
EGS INTERNATIONAL, LLC
2799 SW 34th Avenue
Pembroke Park, FL 33023
Phone: (954) 519-7536 www.egsinternationalllc.com

no.	date	description	by
A	10.30.20	UPDATED TO 2020 FBC	
B	07.05.23	UPDATED TO 2023 FBC	

date: 05-28-19
scale: 3/8"=1'-0"
dr. by: TARIQ
chk. by:

drawing no.
19-46F
sheet 1 of 8

DESIGN LOAD CAPACITY - PSF (GLASS)					
PANEL WIDTH NOMINAL INCHES	DOOR FRAME HEIGHT INCHES	W/O REINF'D INTERLOCKS		WITH ITEM #32 REINF'D INTERLOCKS	
		EXT.(+)	INT.(-)	EXT.(+)	INT.(-)
24	84	80.0	160.0	130.0	130.0
30		80.0	160.0	130.0	130.0
36		80.0	160.0	130.0	130.0
39-1/4		80.0	160.0	130.0	130.0
42		80.0	149.5	130.0	130.0
48		80.0	130.0	130.0	130.0
50		76.8	124.8	130.0	130.0
54		71.1	115.6	130.0	130.0
56		68.6	111.4	125.4	125.4
60		64.0	104.0	117.0	117.0
24	90	80.0	160.0	130.0	130.0
30		80.0	160.0	130.0	130.0
36		80.0	160.0	130.0	130.0
39-1/4		80.0	160.0	130.0	130.0
42		80.0	149.5	130.0	130.0
48		80.0	130.0	130.0	130.0
50		76.8	124.8	130.0	130.0
54		71.1	115.6	130.0	130.0
56		68.6	111.4	125.4	125.4
60		-	-	117.0	117.0
24	96	80.0	160.0	130.0	130.0
30		80.0	160.0	130.0	130.0
36		80.0	160.0	130.0	130.0
39-1/4		80.0	160.0	130.0	130.0
42		80.0	130.0	130.0	130.0
48		80.0	130.0	130.0	130.0
50		76.8	124.8	130.0	130.0
54		71.1	115.6	130.0	130.0
56		-	-	125.4	125.4
60		-	-	117.0	117.0
24	102	80.0	130.0	130.0	130.0
30		80.0	130.0	130.0	130.0
36		80.0	130.0	130.0	130.0
39-1/4		80.0	130.0	130.0	130.0
42		80.0	130.0	130.0	130.0
48		80.0	130.0	130.0	130.0
50		76.8	124.8	130.0	130.0
54		-	-	130.0	130.0
56		-	-	125.4	125.4
60		-	-	117.0	117.0
24	108	80.0	130.0	130.0	130.0
30		80.0	130.0	130.0	130.0
36		80.0	130.0	130.0	130.0
39-1/4		80.0	130.0	130.0	130.0
42		80.0	130.0	130.0	130.0
48		80.0	130.0	130.0	130.0
50		-	-	130.0	130.0
54		-	-	130.0	130.0
56		-	-	125.4	125.4
60		-	-	117.0	117.0

DESIGN LOAD CAPACITY - PSF (GLASS)					
PANEL WIDTH NOMINAL INCHES	DOOR FRAME HEIGHT INCHES	W/O REINF'D INTERLOCKS		WITH ITEM #32 REINF'D INTERLOCKS	
		EXT.(+)	INT.(-)	EXT.(+)	INT.(-)
24	114	-	-	130.0	130.0
30		-	-	130.0	130.0
36		-	-	130.0	130.0
39-1/4		-	-	130.0	130.0
42		-	-	130.0	130.0
48		-	-	130.0	130.0
50		-	-	130.0	130.0
54		-	-	127.9	127.9
56		-	-	122.7	122.7
24		120	-	-	130.0
30	-		-	130.0	130.0
36	-		-	130.0	130.0
39-1/4	-		-	130.0	130.0
42	-		-	130.0	130.0
48	-		-	130.0	130.0
50	-		-	130.0	130.0
54	-		-	121.3	121.3

NOTE:
GLASS CAPACITIES ON THIS SHEET ARE
BASED ON ASTM E1300-09 (3 SEC. GUSTS)
AND FLORIDA BUILDING COMMISSION
DECLARATORY STATEMENT DCA05-DEC-219

PANEL HEIGHT = DOOR HEIGHT - 2"

(INTERPOLATION BETWEEN WIDTHS ALLOWED)

SHOWN CAPACITIES ARE FOR
4.938" SILL HEIGHTS
LIMIT EXTERIOR(+) LOADS AS FOLLOWS
3.750" SILL HT. = +80.0 PSF
3.188" SILL HT. = +53.3 PSF

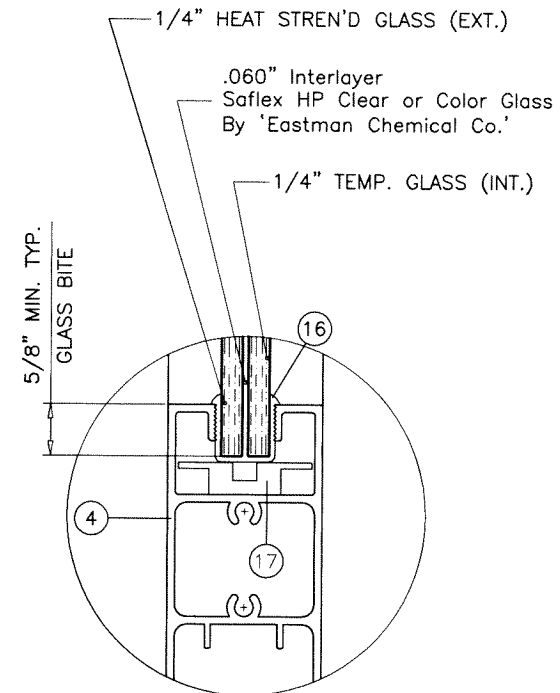

GLAZING DETAIL

Sealed: 7/12/2023

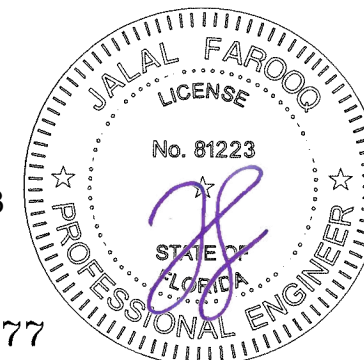

FL #29677

AL-FAROOQ CORPORATION
ENGINEERS & PRODUCT DEVELOPMENT
9360 SUNSET DRIVE, SUITE 220
MIAMI, FLORIDA 33173 (C.A.N. 3538)
TEL. (305) 264-8100 FAX. (305) 262-6978
EGS\SM\19-46F-EGS

ATLANTIC SERIES SM 130 ALUM. SLIDING GLASS DOOR
EGS INTERNATIONAL, LLC
2799 SW 34th Avenue
Pembroke Park, FL 33023
Phone: (954) 519-7536 www.egsinternationalllc.com

no	date	by	description

date: 05-28-19
scale: 1/2" = 1"
dr. by: TARIQ
chk. by:

drawing no.
19-46F
sheet 2 of 8

ANCHOR LOAD CAPACITY - PSF				
ANCHOR TYPES		'A'	'B' & 'C'	
PANEL WIDTH NOMINAL INCHES	DOOR HEIGHT INCHES	6 ANCHORS AT MTG. STILE ENDS	4 ANCHORS AT MTG. STILE ENDS	6 ANCHORS AT MTG. STILE ENDS
		EXT. (+) INT. (-)	EXT. (+) INT. (-)	EXT. (+) INT. (-)
24	84	160.0	160.0	160.0
30		160.0	160.0	160.0
36		160.0	160.0	160.0
39-1/4		160.0	160.0	160.0
42		149.5	149.5	149.5
48		130.0	130.0	130.0
50		130.0	130.0	130.0
54		130.0	130.0	130.0
56		125.4	125.4	125.4
60		117.0	117.0	117.0
24	90	160.0	160.0	160.0
30		160.0	160.0	160.0
36		160.0	160.0	160.0
39-1/4		157.2	157.2	160.0
42		149.5	149.5	149.5
48		130.0	130.0	130.0
50		130.0	130.0	130.0
54		127.7	127.7	130.0
56		125.1	125.1	125.4
60		117.0	117.0	117.0
24	96	160.0	160.0	160.0
30		160.0	160.0	160.0
36		154.7	154.7	160.0
39-1/4		144.9	144.9	160.0
42		130.0	130.0	130.0
48		125.7	125.7	130.0
50		122.3	122.3	130.0
54		116.6	116.6	130.0
56		114.1	114.1	125.4
60		109.7	109.7	117.0
24	102	130.0	130.0	130.0
30		130.0	130.0	130.0
36		130.0	130.0	130.0
39-1/4		130.0	130.0	130.0
42		127.7	127.7	130.0
48		116.0	116.0	130.0
50		112.8	112.8	130.0
54		107.2	107.2	130.0
56		104.8	104.8	125.4
60		100.5	100.5	117.0
24	108	130.0	130.0	130.0
30		130.0	130.0	130.0
36		130.0	130.0	130.0
39-1/4		125.2	125.2	130.0
42		118.9	118.9	130.0
48		107.7	107.7	130.0
50		104.7	104.7	130.0
54		99.3	99.3	130.0
56		96.9	96.9	125.4
60		92.8	92.8	117.0

ANCHOR LOAD CAPACITY - PSF				
ANCHOR TYPES		'A'	'B' & 'C'	
PANEL WIDTH NOMINAL INCHES	DOOR HEIGHT INCHES	6 ANCHORS AT MTG. STILE ENDS	4 ANCHORS AT MTG. STILE ENDS	6 ANCHORS AT MTG. STILE ENDS
		EXT. (+) INT. (-)	EXT. (+) INT. (-)	EXT. (+) INT. (-)
24	114	130.0	130.0	130.0
30		130.0	130.0	130.0
36		125.7	125.7	130.0
39-1/4		117.2	117.2	130.0
42		111.2	111.2	130.0
48		100.5	100.5	130.0
50		97.6	97.6	130.0
54		92.4	92.4	130.0
56		90.2	90.2	127.9
60		86.2	86.2	122.7
24	120	130.0	130.0	130.0
30		130.0	130.0	130.0
36		118.3	118.3	130.0
39-1/4		110.2	110.2	130.0
42		104.5	104.5	130.0
48		94.3	94.3	130.0
50		91.4	91.4	130.0
54		86.5	86.5	121.3

ANCHOR TYPES A, B, C APPLICABLE AT HEAD
ANCHOR TYPE B APPLICABLE AT SILL

TYPICAL ANCHORS: SEE ELEV. FOR SPACING

AT HEAD

TYPE 'A' - 1/4" DIA. ULTRACON+ BY 'DEWALT' (Fu=164 KSI, Fy=148 KSI)
 INTO 2BY WOOD BUCKS OR WOOD STRUCTURES
 1-1/2" MIN. PENETRATION INTO WOOD
 THRU 1BY BUCKS INTO CONCRETE
 1-1/4" MIN. EMBED INTO CONCRETE

TYPE 'B' - 1/4" DIA. ULTRACON+ BY 'DEWALT' (Fu=164 KSI, Fy=148 KSI)
 DIRECTLY INTO CONCRETE
 1-3/4" MIN. EMBED

TYPE 'C' - 1/4" DIA. SELF DRILLING SCREWS (GRADE 5 CRS)
 INTO F.B.C. APPROVED MULLIONS
 OR
 INTO METAL STRUCTURES (HEAD/JAMBS)
 (3) THREADS MIN. TO EXTEND BEYOND METAL THICKNESS
 ALUMINUM: 1/8" THK. MIN. (6063-T5 MIN.)
 STEEL: 1/8" THK. MIN. (Fy = 36 KSI MIN.)
 (STEEL IN CONTACT WITH ALUMINUM TO BE PLATED OR PAINTED)

AT SILL

TYPE 'B' - 1/4" DIA. ULTRACON+ BY 'DEWALT' (Fu=164 KSI, Fy=148 KSI)
 DIRECTLY INTO CONCRETE
 1-3/4" MIN. EMBED

AT JAMBS

TYPE 'A' - 1/4" DIA. ULTRACON+ BY 'DEWALT' (Fu=164 KSI, Fy=148 KSI)
 INTO 2BY WOOD BUCKS OR WOOD STRUCTURES
 1-1/2" MIN. PENETRATION INTO WOOD
 THRU 1BY BUCKS INTO CONC. OR BLOCKS
 1-1/4" MIN. EMBED INTO CONC. OR BLOCKS

TYPE 'B' - 1/4" DIA. ULTRACON+ BY 'DEWALT' (Fu=164 KSI, Fy=148 KSI)
 DIRECTLY INTO CONC. OR FILLED BLOCKS
 1-3/4" MIN. EMBED INTO CONCRETE
 1-1/4" MIN. EMBED INTO BLOCKS

TYPE 'C' - #14 SMS OR SELF DRILLING SCREWS (GRADE 5 CRS)
 INTO F.B.C. APPROVED MULLIONS
 OR
 INTO METAL STRUCTURES (HEAD/JAMBS)
 (3) THREADS MIN. TO EXTEND BEYOND METAL THICKNESS
 ALUMINUM: 1/8" THK. MIN. (6063-T5 MIN.)
 STEEL: 1/8" THK. MIN. (Fy = 36 KSI MIN.)
 (STEEL IN CONTACT WITH ALUMINUM TO BE PLATED OR PAINTED)

ANCHOR EDGE DISTANCES
 INTO CONCRETE = 2-1/2" MIN.
 INTO WOOD STRUCTURE = 1" MIN.
 INTO METAL STRUCTURE = 3/4" MIN.
 WOOD AT HEAD, SILL OR JAMBS SG = 0.55 MIN.
 CONCRETE AT HEAD, SILL OR JAMBS f'c = 3000 PSI MIN.
 C-90 HOLLOW/FILLED BLOCK AT JAMBS f'm = 2000 PSI MIN.

Sealed: 7/12/2023

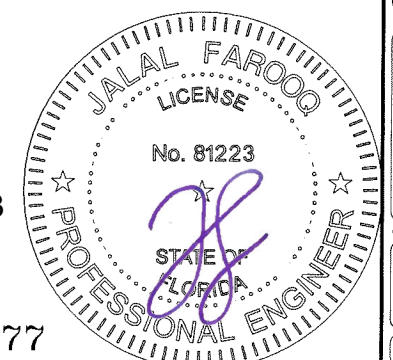

FL #29677

a f c
AL-FAROOQ CORPORATION
 ENGINEERS & PRODUCT DEVELOPMENT
 9360 SUNSET DRIVE, SUITE 220 (C.A.N. 3538)
 MIAMI, FLORIDA 33173
 TEL. (305) 264-8100 FAX. (305) 262-6978
 EGS\SM\19-46F-EGS

ATLANTIC SERIES SM 130 ALUM. SLIDING GLASS DOOR
EGS INTERNATIONAL, LLC
 2799 SW 34th Avenue
 Pembroke Park, FL 33023
 Phone: (954) 519-7536 www.egsinternationalllc.com

no.	date	by	description

date: 05-28-19	scale: 1/2"=1'-0"	dr. by: TARIQ	chk. by:
----------------	-------------------	---------------	----------

drawing no.	19-46F
sheet	3 of 8

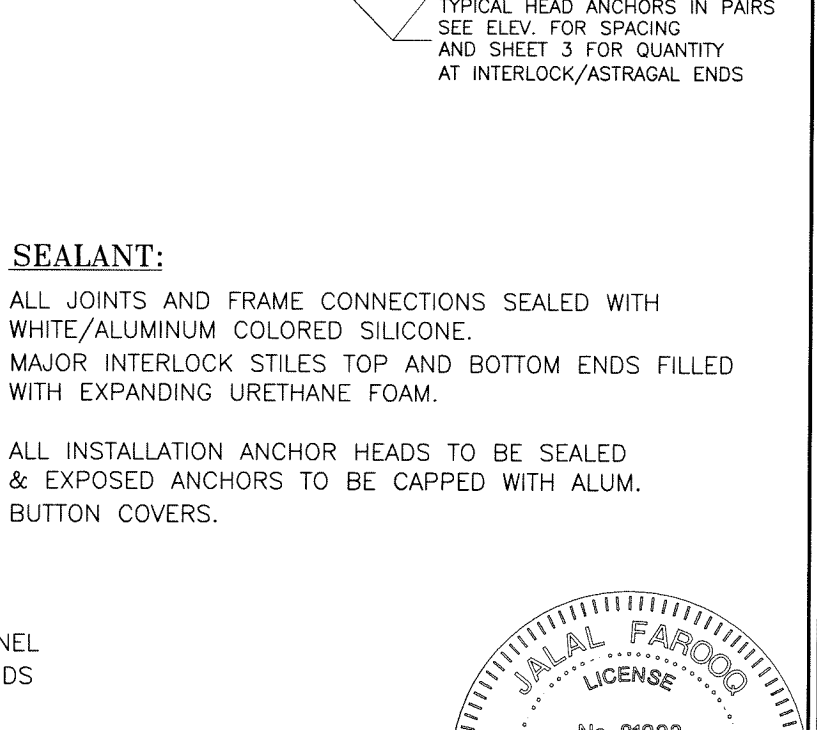
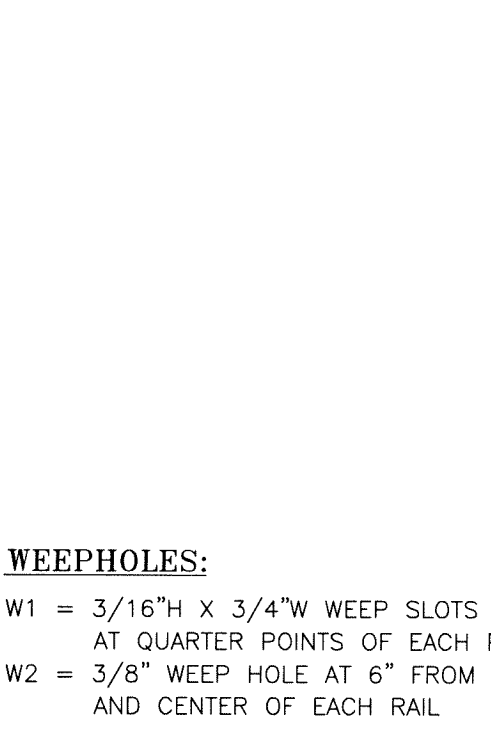
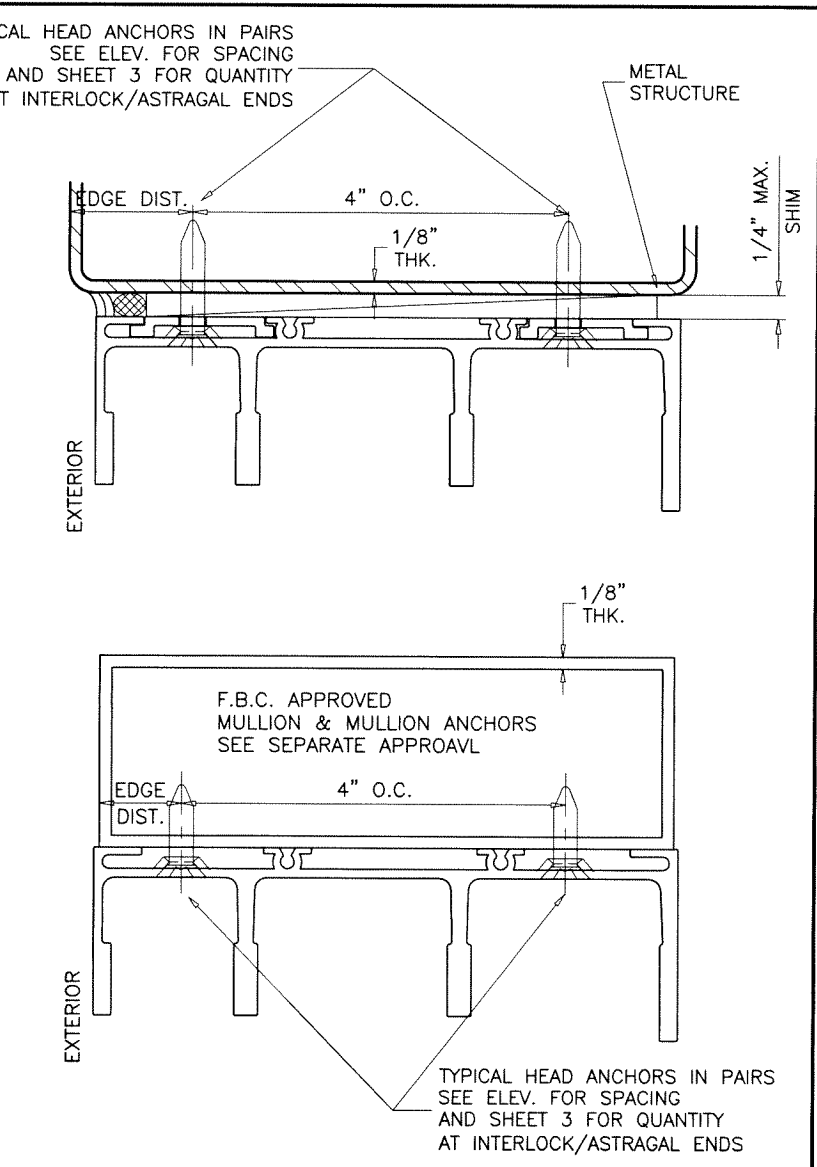
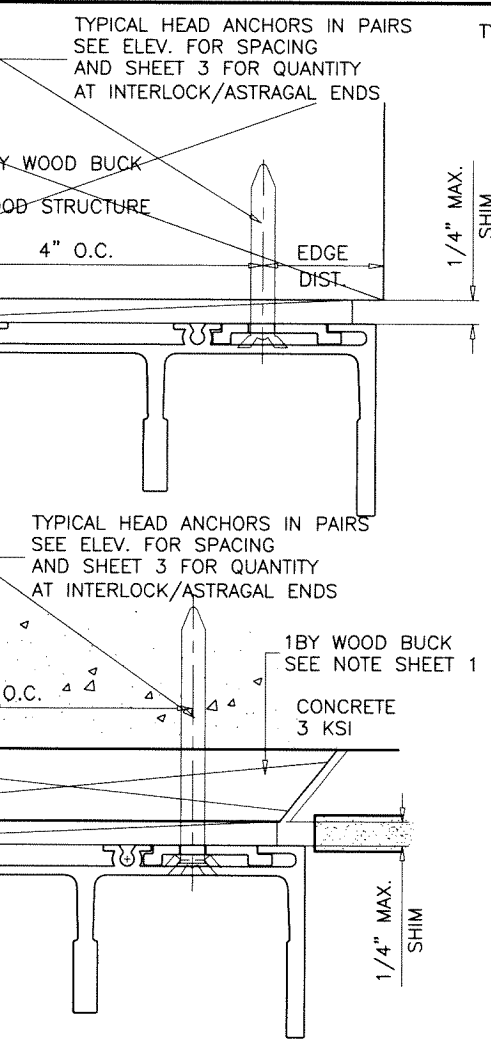
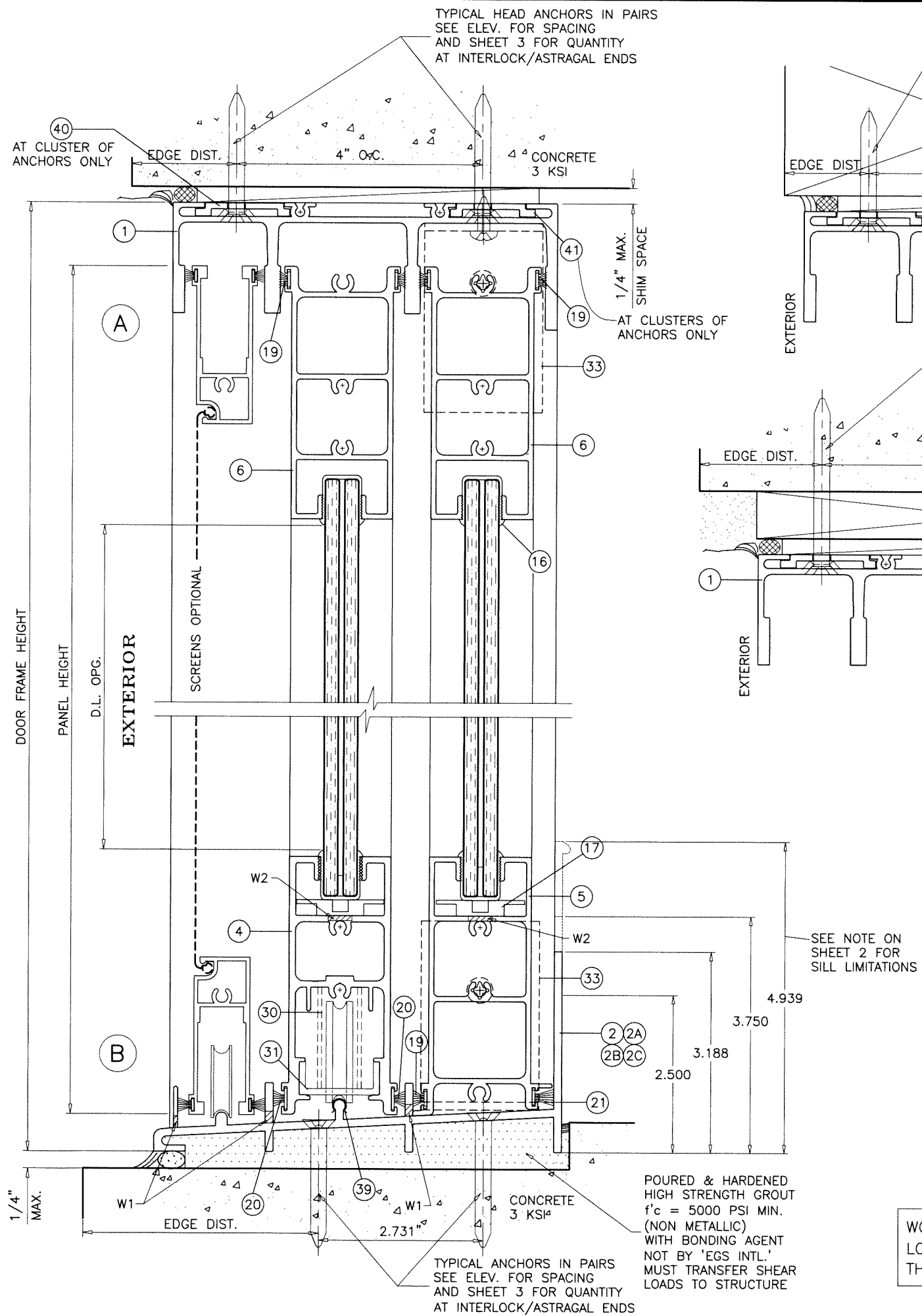

SEALANT:
 ALL JOINTS AND FRAME CONNECTIONS SEALED WITH WHITE/ALUMINUM COLORED SILICONE.
 MAJOR INTERLOCK STILES TOP AND BOTTOM ENDS FILLED WITH EXPANDING URETHANE FOAM.

ALL INSTALLATION ANCHOR HEADS TO BE SEALED & EXPOSED ANCHORS TO BE CAPPED WITH ALUM. BUTTON COVERS.

WEEPHOLES:
 W1 = 3/16" H X 3/4" W WEEP SLOTS AT QUARTER POINTS OF EACH PANEL
 W2 = 3/8" WEEP HOLE AT 6" FROM ENDS AND CENTER OF EACH RAIL

WOOD BUCKS NOT BY 'EGS INTL.', MUST SUSTAIN LOADS IMPOSED BY GLAZING SYSTEM AND TRANSFER THEM TO THE BUILDING STRUCTURE.

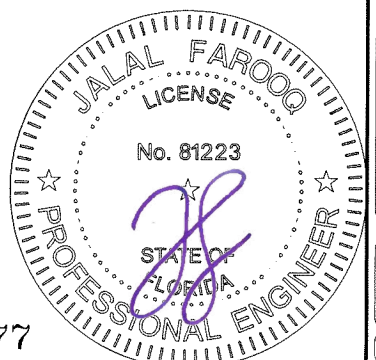

Sealed: 7/12/2023

FL #29677

af c
AL-FAROOQ CORPORATION
 ENGINEERS & PRODUCT DEVELOPMENT
 9360 SUNSET DRIVE, SUITE 220
 MIAMI, FLORIDA 33173 (C.A.N. 3538)
 TEL. (305) 264-8100 FAX. (305) 262-6978
 EGS\SM\19-46F-EGS

ATLANTIC SERIES SM 130 ALUM. SLIDING GLASS DOOR
EGS INTERNATIONAL, LLC
 2799 SW 34th Avenue
 Pembroke Park, FL 33023
 Phone: (954) 519-7536 www.egsinternational.com

no	date	description

date: 05-28-19
 scale: 1/2" = 1"
 dr. by: TARIQ
 chk. by:

drawing no.
19-46F
 sheet 4 of 8

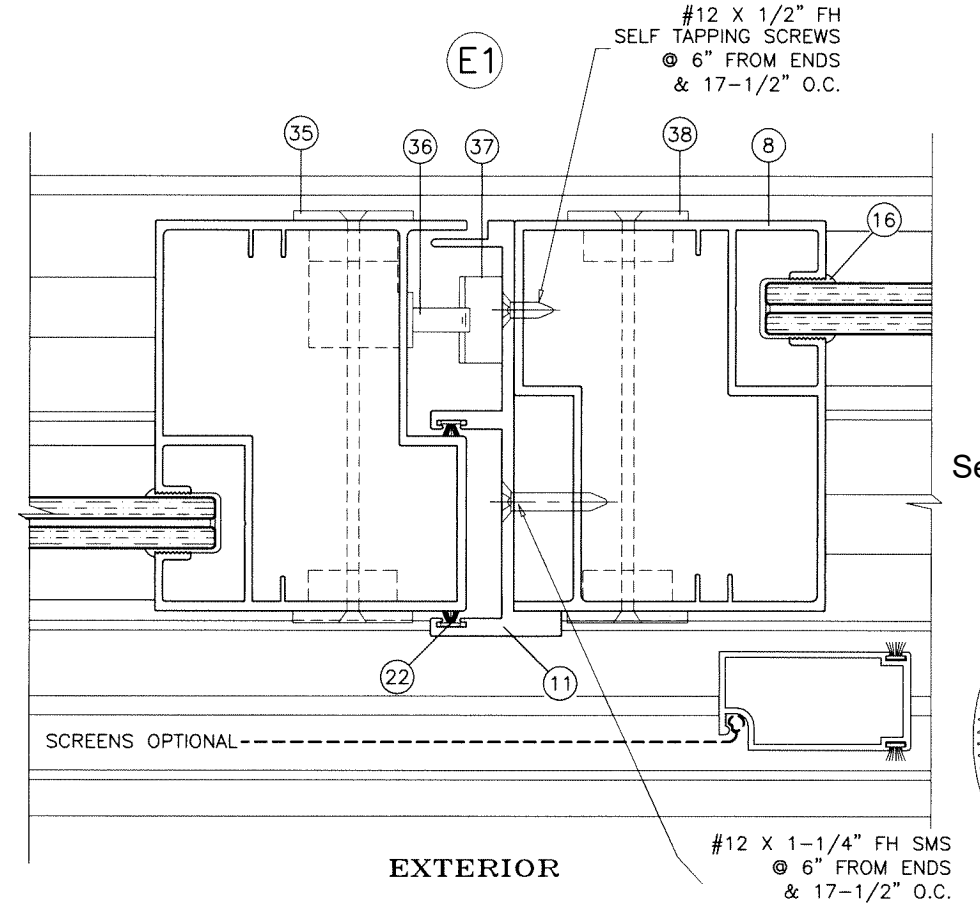
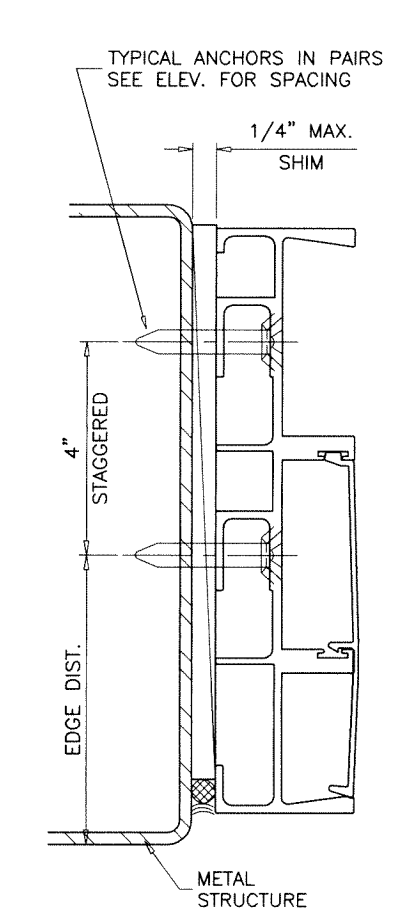
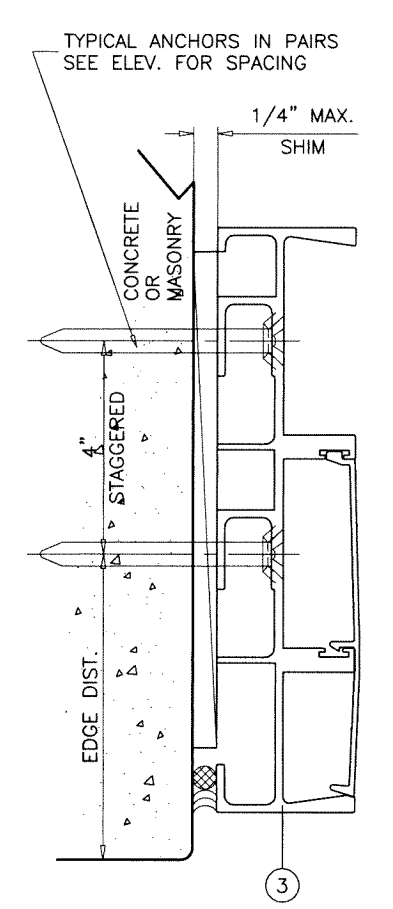
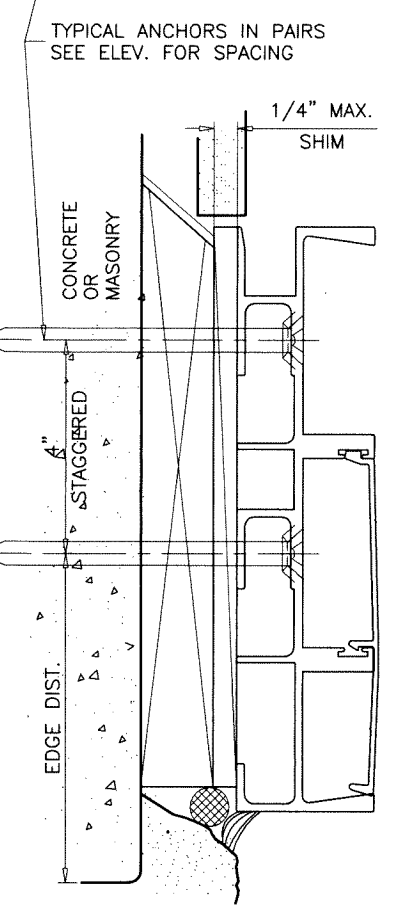
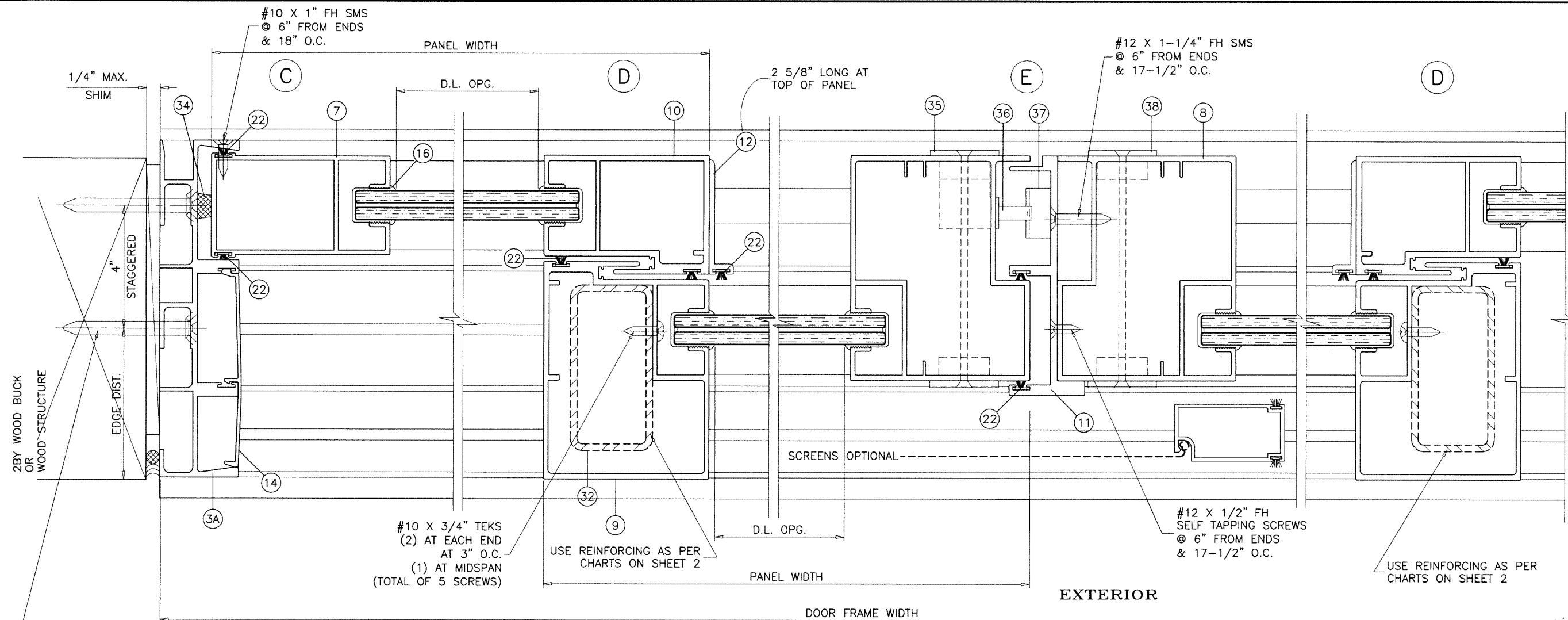

Sealed: 7/12/2023
 FL #29677

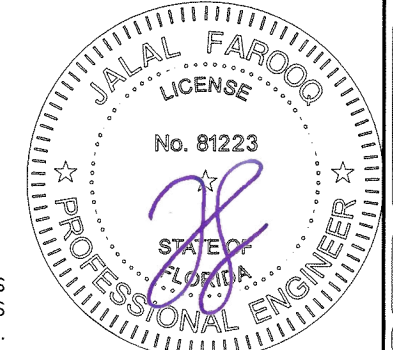

AL-FAROOQ CORPORATION
 ENGINEERS & PRODUCT DEVELOPMENT
 9360 SUNSET DRIVE, SUITE 220
 MIAMI, FLORIDA 33173 (C.A.N. 3538)
 TEL. (305) 264-8100 FAX. (305) 262-6978
 EGS\SM\19-46F-EGS

ATLANTIC SERIES SM 130 ALUM. SLIDING GLASS DOOR
EGS INTERNATIONAL, LLC
 2799 SW 34th Avenue
 Pembroke Park, FL 33023
 Phone: (954) 519-7536 www.egsinternational.com

no	date	by	description

date: 05-28-19
 scale: 1/2" = 1"
 dr. by: TARIQ
 chk. by:

drawing no.
19-46F
 sheet 5 of 8

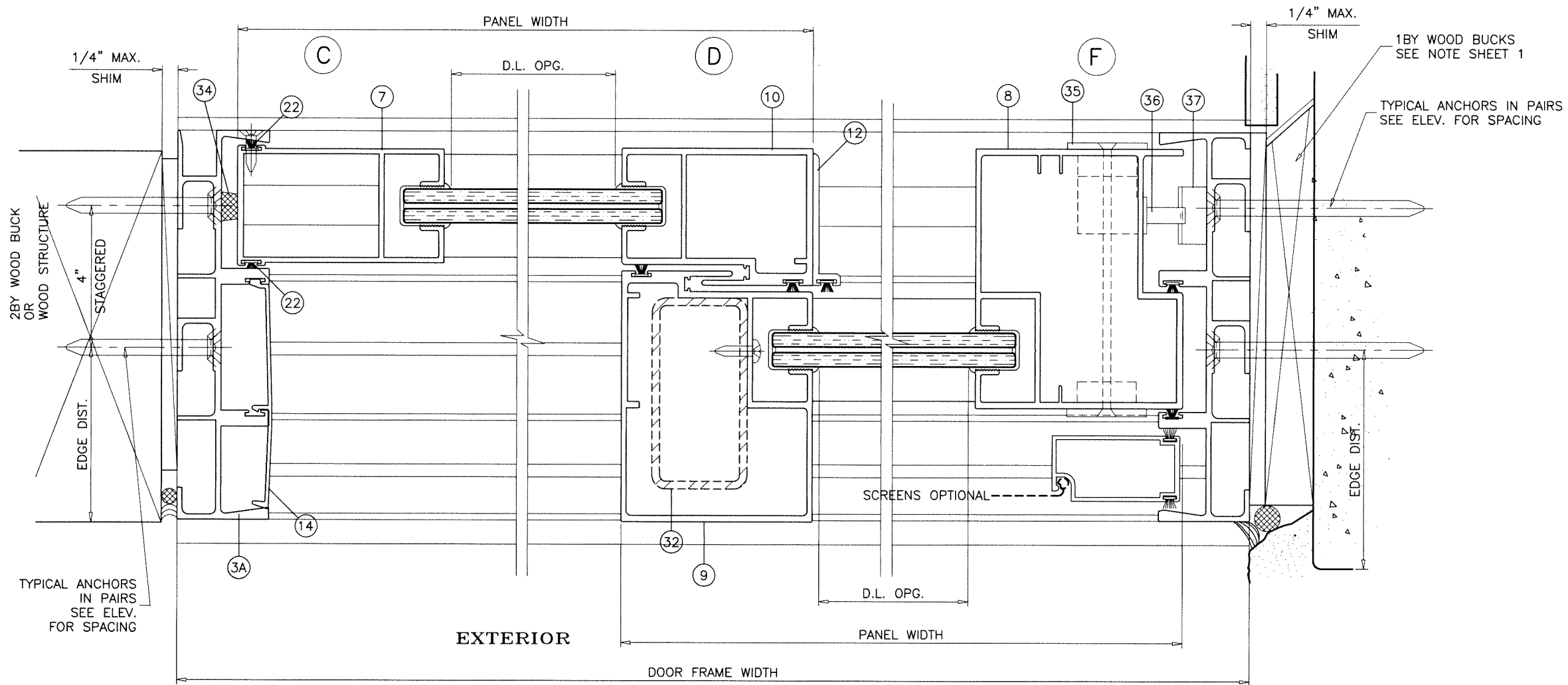

Sealed: 7/12/2023

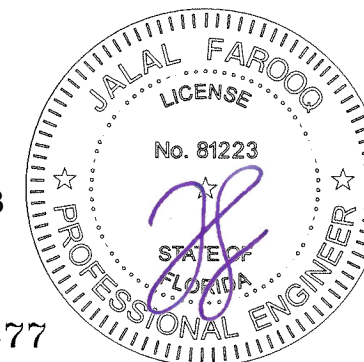

FL #29677

af c
AL-FAROOQ CORPORATION
ENGINEERS & PRODUCT DEVELOPMENT
9360 SUNSET DRIVE, SUITE 220 (C.A.N. 3538)
MIAMI, FLORIDA 33173
TEL. (305) 264-8100 FAX. (305) 262-6978
EGS\SM\19-46F-EGS

ATLANTIC SERIES SM 130 ALUM. SLIDING GLASS DOOR
EGS INTERNATIONAL, LLC
2799 SW 34th Avenue
Pembroke Park, FL 33023
Phone: (954) 519-7536 www.egsinternationalllc.com

no.	date	by	description

date: 05-28-19
scale: 1/2" = 1"
dr. by: TARIQ
chk. by:

drawing no.
19-46F
sheet 6 of 8

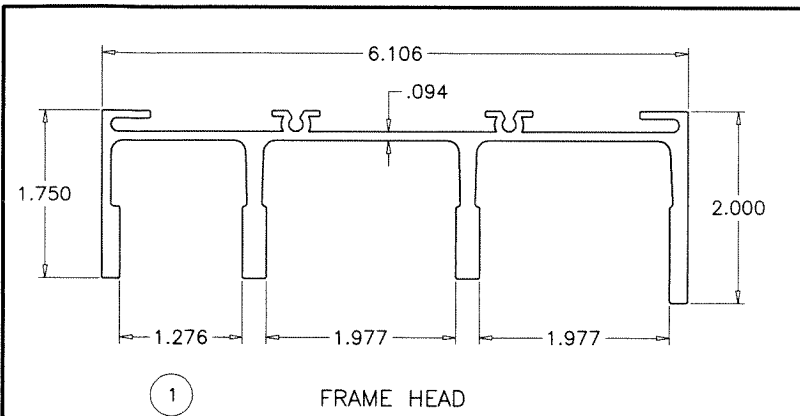

1 FRAME HEAD

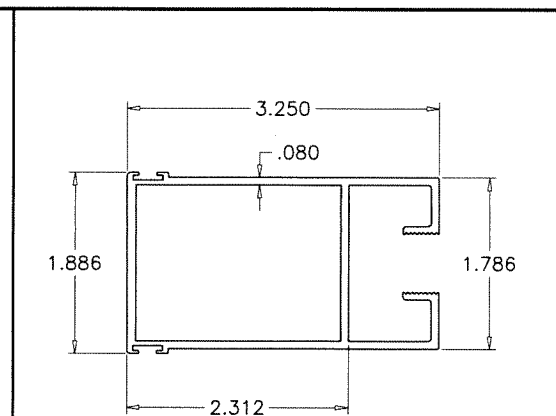

7 FIXED STILE

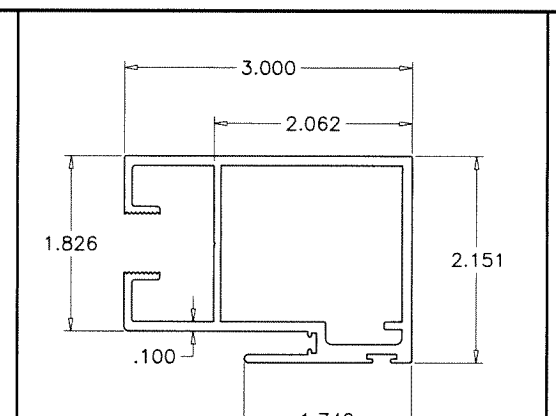

10 MINOR INTERLOCK

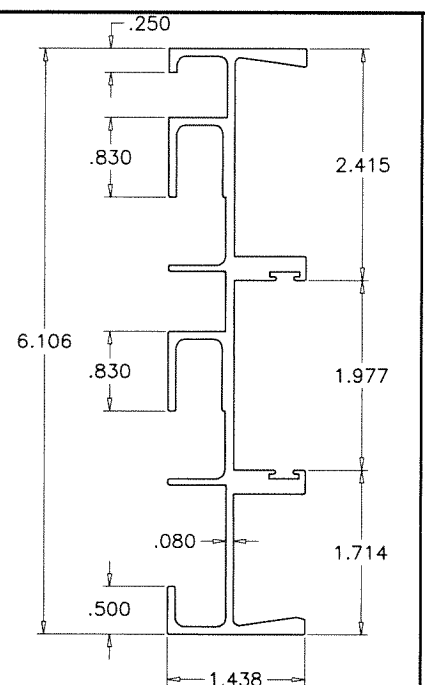

3 FRAME JAMB W/O POCKET

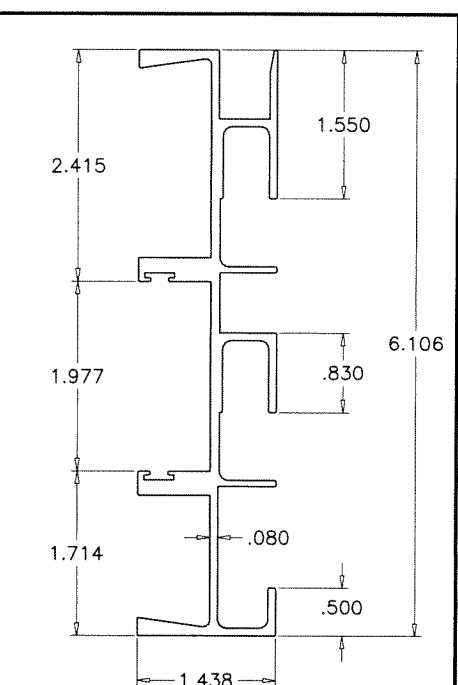

3A FRAME JAMB WITH POCKET

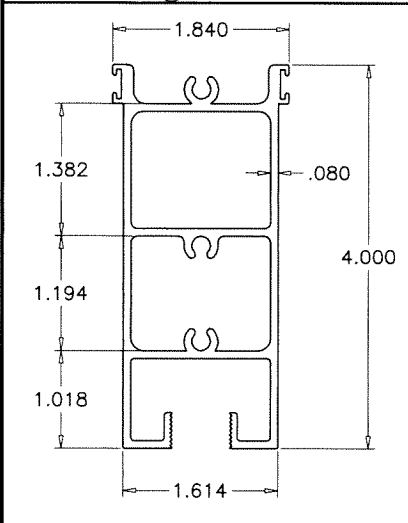

6 TOP RAIL

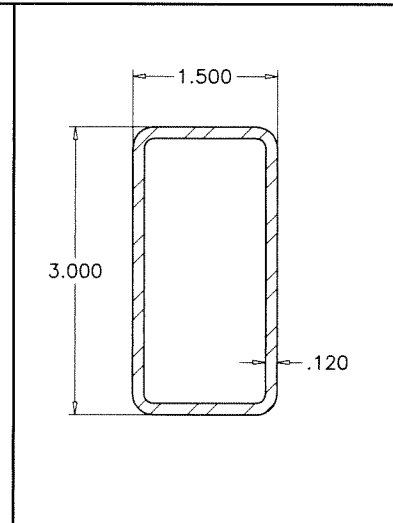

32 REINFORCING TUBE

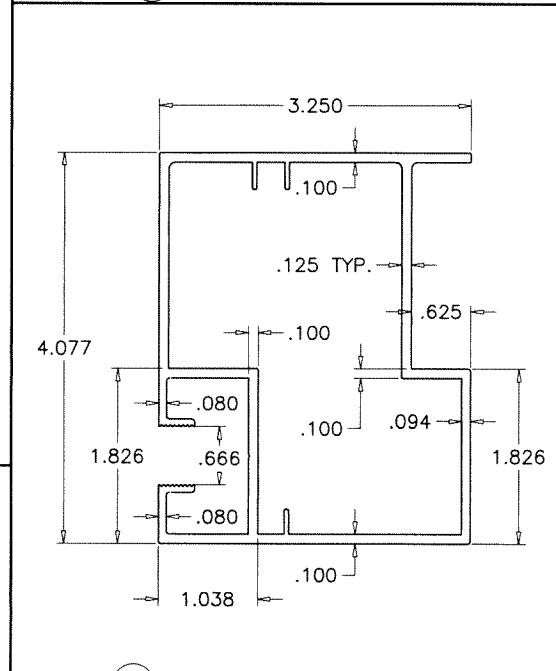

8 LOCKING STILE

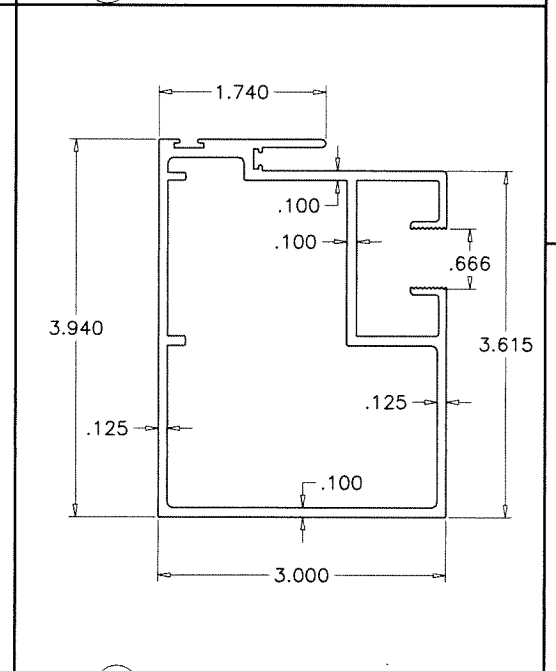

9 MAJOR INTERLOCK

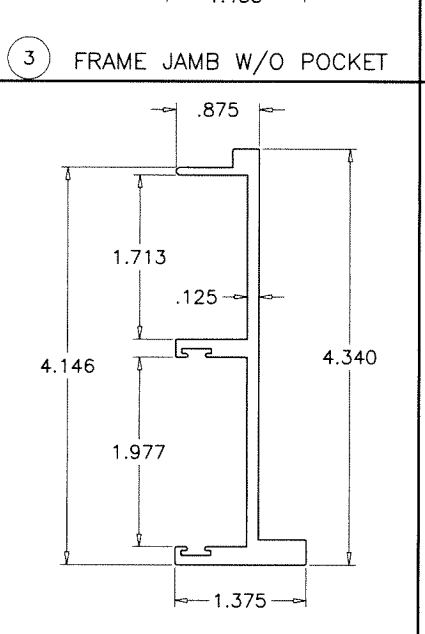

11 STILE ADAPTER

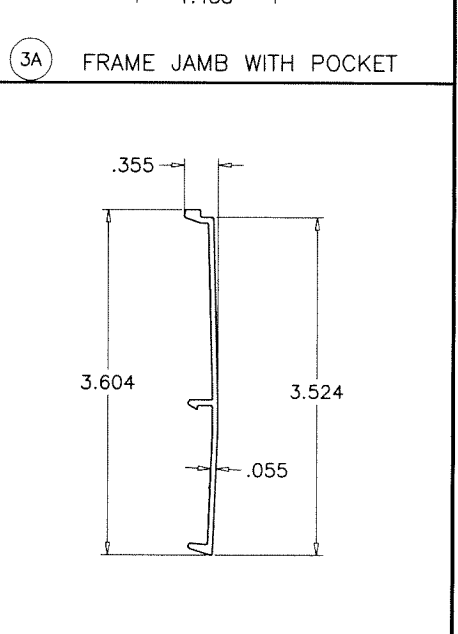

14 JAMB COVER

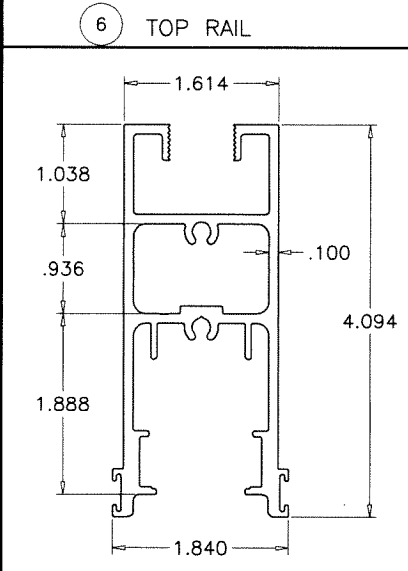

4 MOVING BOTTOM RAIL

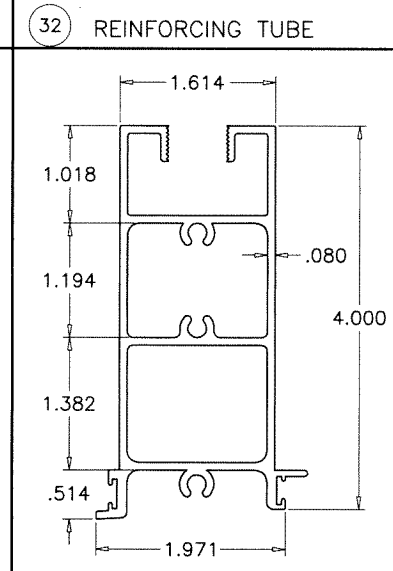

5 FIXED BOTTOM RAIL

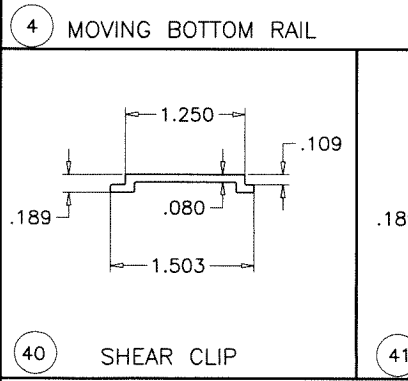

40 SHEAR CLIP

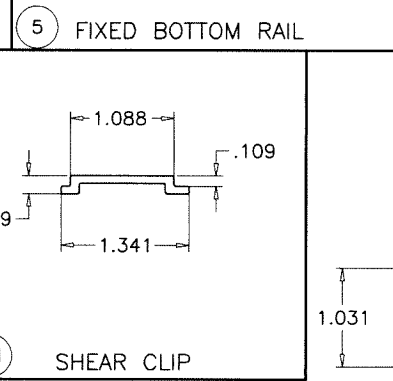

41 SHEAR CLIP

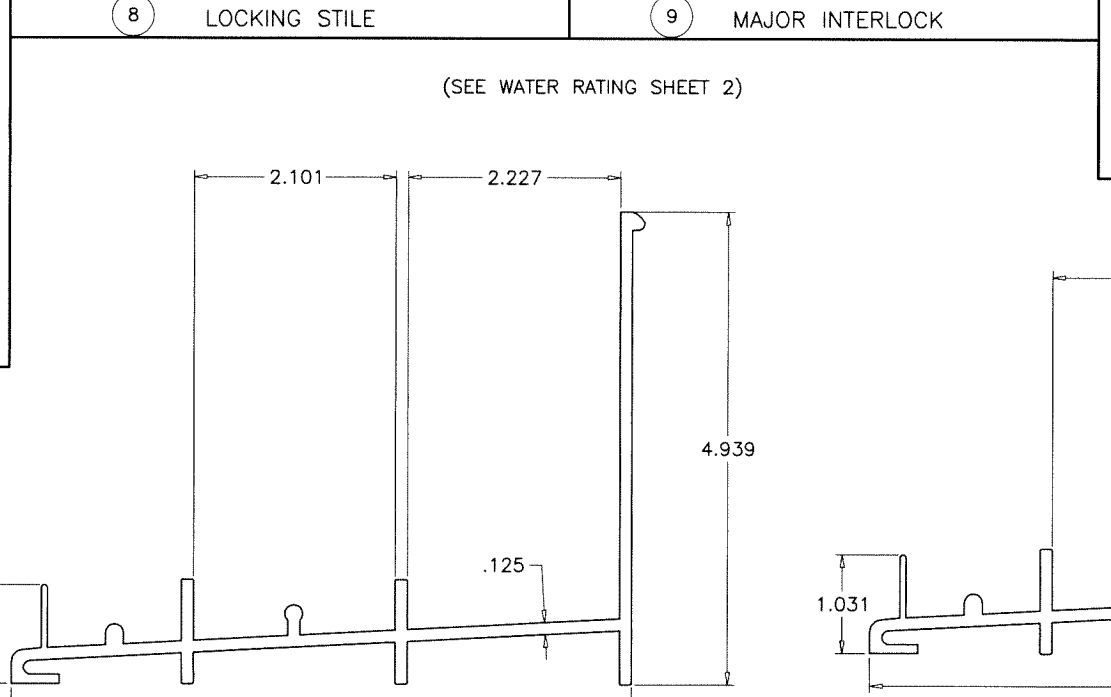

2B FRAME SILL

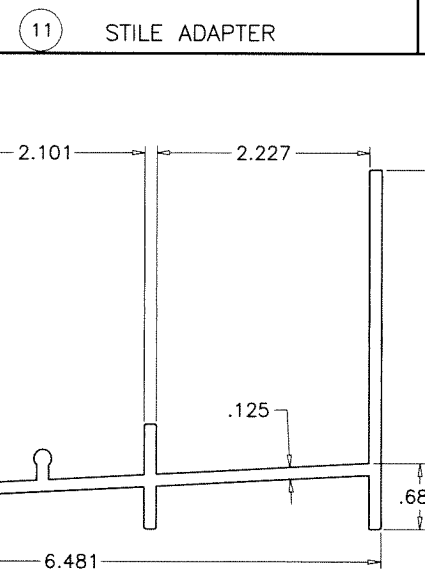

2 2A 2C FRAME SILL

S.M.I. = SMALL MISSILE IMPACT GLASS SHAPES

(SEE WATER RATING SHEET 2)

Sealed: 7/12/2023

FL #29677

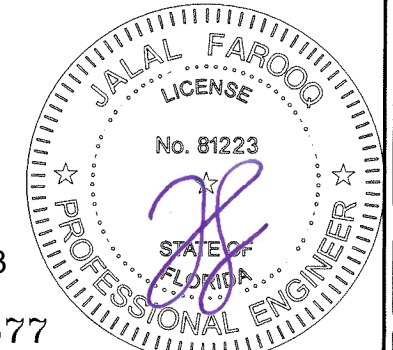

af c
AL-FAROOQ CORPORATION
 ENGINEERS & PRODUCT DEVELOPMENT
 9360 SUNSET DRIVE, SUITE 220
 MIAMI, FLORIDA 33173 (C.A.N. 3538)
 TEL. (305) 264-8100 FAX. (305) 262-6978
 EGS\SM\19-46F-EGS

ATLANTIC SERIES SM 130 ALUM. SLIDING GLASS DOOR
EGS INTERNATIONAL, LLC
 2799 SW 34th Avenue
 Pembroke Park, FL 33023
 Phone: (954) 519-7536 www.egsinternationalllc.com

no	date	description

date: 05-28-19
 scale: 1/2" = 1"
 dr. by: TARIQ
 chk. by:

drawing no.
19-46F
 sheet 7 of 8

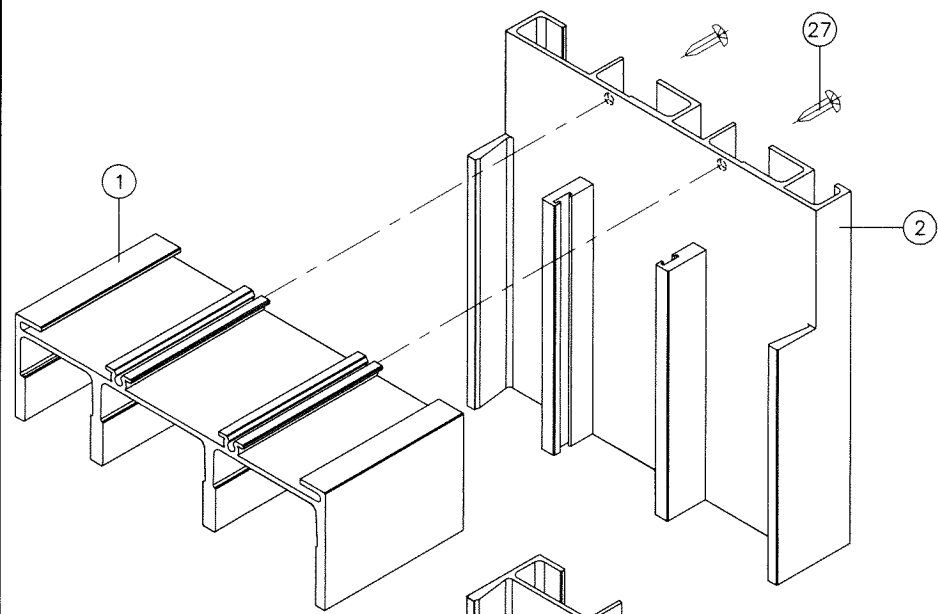

FRAME TOP CORNER

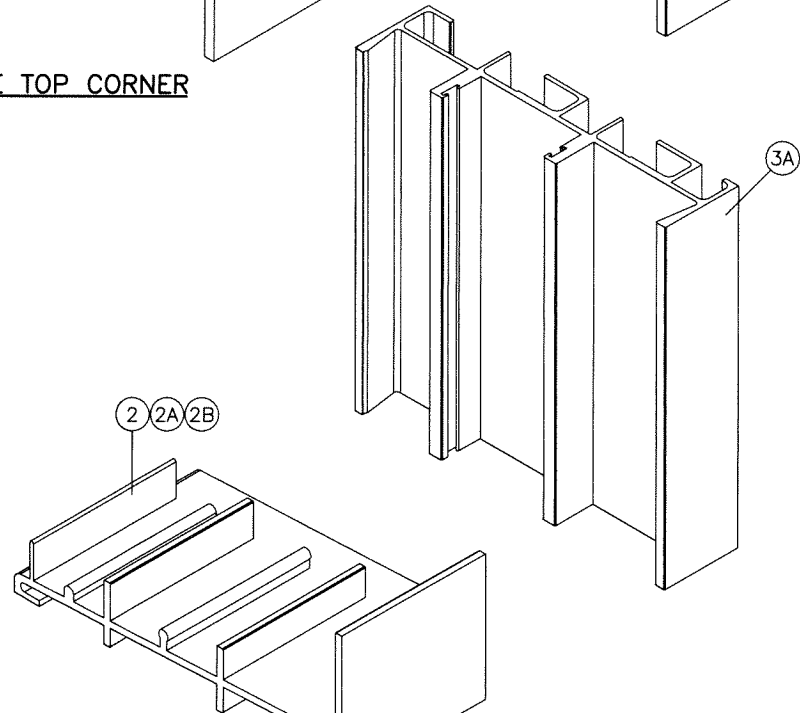

FRAME BOTTOM CORNER

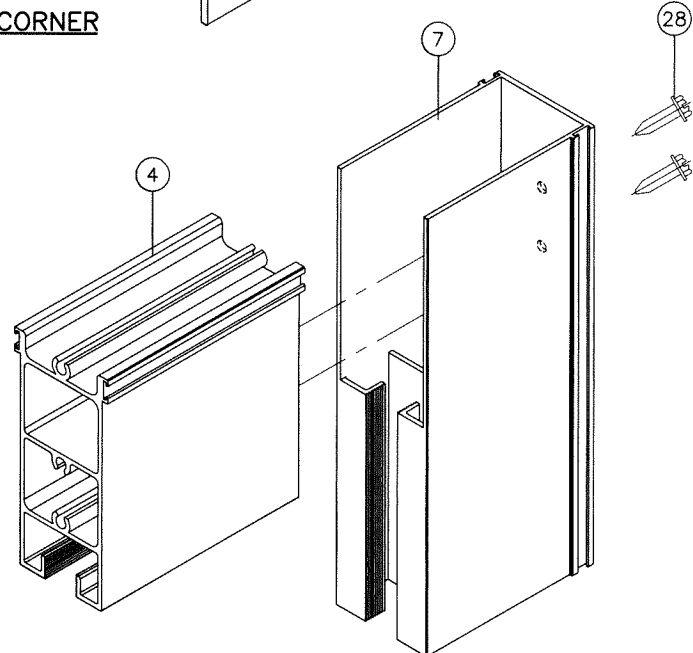

PANEL CORNER

ITEM NO.	PART NUMBER	QUANTITY	DESCRIPTION	MATERIAL	MANF./SUPPLIER/REMARKS
1	EGS-551	1	FRAME HEAD	6005-T5/6105-T5	-
2	EGS-580	1	FRAME SILL (3-3/16" HIGH)	6005-T5/6105-T5	-
2A	EGS-581	1	FRAME SILL (3-3/4" HIGH)	6005-T5/6105-T5	-
2B	EGS-552	1	FRAME SILL (4-15/16" HIGH)	6005-T5/6105-T5	-
2C	EGS-580	1	FRAME SILL (2-1/2" HIGH)	6005-T5/6105-T5	-
3	EGS-567	2	FRAME JAMB W/O POCKET	6005-T5/6105-T5	-
3A	EGS-553	2	ALT. FRAME JAMB W/ POCKET	6005-T5/6105-T5	-
4	EGS-573	1/MOV. PANEL	MOVING BOTT. RAIL (S.M.I.)	6005-T5/6105-T5	-
5	EGS-572	1/FIX. PANEL	FIXED BOTT. RAIL (S.M.I.)	6005-T5/6105-T5	-
6	EGS-571	1/PANEL	TOP RAIL (S.M.I.)	6005-T5/6105-T5	-
7	EGS-574	AS REQD.	FIXED STILE (S.M.I.)	6005-T5/6105-T5	-
8	EGS-575	AS REQD.	LOCKING STILE (S.M.I.)	6005-T5/6105-T5	-
9	EGS-576	AS REQD.	MAJOR INTERLOCK (S.M.I.)	6005-T5/6105-T5	-
10	EGS-577	AS REQD.	MINOR INTERLOCK (S.M.I.)	6005-T5/6105-T5	-
11	EGS-561	AS REQD.	STILE ADAPTER	6005-T5/6105-T5	-
12	EGS-566	AS REQD.	DOOR SWEEP	6063-T5/6105-T5	AT TOP OF FIXED PANEL
14	EGS-570	AS REQD.	JAMB COVER	6063-T5/6105-T5	OPTIONAL
16	EGS-72	AS REQD.	9/16" GLAZING GASKET	SOFT PVC	TEAMPLASTICS (BVC INC.)
17	TX11429E	2/ LITE	SETTING BLOCKS, 4" LONG, @ 10" FROM EACH END	EPDM	TREMCO
19	28027045/7527-6011-4	AS REQD.	FINSEAL WOOLPILE AT HORIZ. RAILS	-	AMESBURY
20	T-2836G	AS REQD.	POLYBOND FINSEAL AT MOV. BOTTOM RAIL	-	ULTRAFAB (.280H X .360 BASE)
21	38027045/7537-6011-6	AS REQD.	FINSEAL WOOLPILE AT FIX. BOTTOM RAIL	-	AMESBURY
22	21027045/7420-6011-2	AS REQD.	FINSEAL WOOLPILE AT VERT. STILES & SWEEP	-	AMESBURY
27	#8 X 3/4"	2/ CORNER	FRAME ASSEMBLY SCREWS	ST. STEEL	PH SMS
28	#12 X 1"	2/ CORNER	PANEL ASSEMBLY SCREWS	ST. STEEL	TH SMS
30	-	2/ MOV. PANEL	TANDEM ACETAL WHEELS IN METALLIC HOUSING	-	DUAL ROLLERS
31	-	1/ MOV. PANEL	ALUM CHANNEL, FULL WIDTH OF PANEL (BOTH OPTIONS)	6063-T5	-
32	-	AS REQD.	INTERLOCK REINFORCEMENT	STEEL	1 1/2" X 3" X 11 G.A.
33	-	AS REQD.	FIX. PANEL CLIP (AT FRAME HEAD/SILL)	ALUMINUM	2 X 3 X 1/8" X 1-7/8" LONG
34	-	AS REQD.	RUBBER BUMPER	-	1/2" X 1/2" SQ. X 3/16" HIGH
35	4430-00-08 OR W5208-NPV30	1	TRIMSET PULL	ABS RESIN OR BRASS (PVD)	ADAMS-RITE OR ASHLAND
36	MS1847-09	1	DEAD LOCK, MOUNTED W/ (2) #6 X 1/4" FH SCREWS	ST. STEEL	ADAMS-RITE
37	4801-05	1	STRIKE, MOUNTED W/ (2) #8 X 1" PH SCREWS & PLASTIC SHIM	ST. STEEL	ADAMS-RITE
38	4432 OR W5208-PP30	1	DUMMY TRIMSET PULL	ABS RESIN OR BRASS (PVD)	ADAMS-RITE OR ASHLAND
39	TC2	1	TRACK COVER	ST/ST	HYGRADE
40	EGS-584	AS REQD.	SHEAR CLIP AT CLUSTERS ONLY	6005-T5/6105-T5	-
41	EGS-584	AS REQD.	SHEAR CLIP AT CLUSTERS ONLY	6005-T5/6105-T5	-

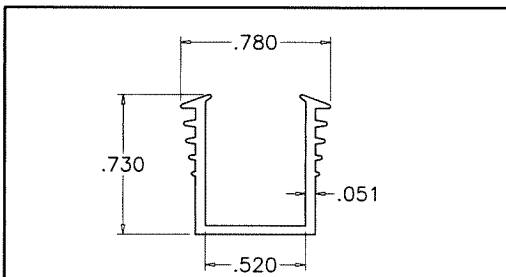

HARDNESS = 85 SHORE A
 TENSILE STRENGTH (BREAK) = 1810 PSI
 ELONGATION AT BREAK = 320%
 TEAR STRENGTH = 260 LBF/IN
 SPECIFIC GRAVITY = 1.45

GLAZING GASKET
 SCALE 1:1

16

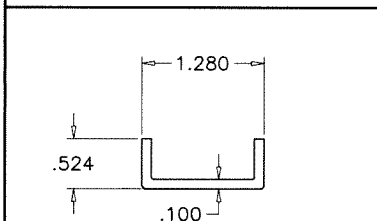

MOV. PANEL REINF.

31

Sealed: 7/12/2023

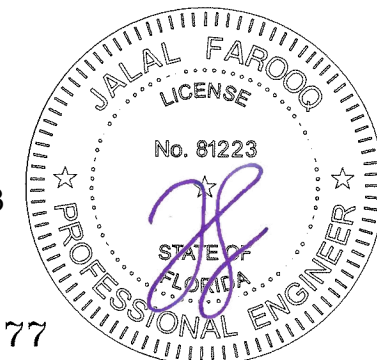

FL #29677

AL-FAROOQ CORPORATION
 ENGINEERS & PRODUCT DEVELOPMENT
 9360 SUNSET DRIVE, SUITE 220
 MIAMI, FLORIDA 33173
 TEL. (305) 264-8100 FAX. (305) 262-6978
 EGS\SM\19-46F-EGS

ATLANTIC SERIES SM 130 ALUM. SLIDING GLASS DOOR
EGS INTERNATIONAL, LLC
 2799 SW 34th Avenue
 Pembroke Park, FL 33023
 Phone: (954) 519-7536 www.egsinternationalllc.com

no	date	description

date: 05-28-19
 scale: 1/2" = 1"
 dr. by: TARIQ
 chk. by:

drawing no.
19-46F
 sheet 8 of 8